

2023 KCATM High School Math Contest

Name: _____

Grade: _____

High School: _____

e-mail address: _____

phone number: _____

INSTRUCTIONS

The following test consists of 20 questions. Use whatever resources you like to solve these problems. Each question is worth 5 points. Partial credit will be given for making progress. However, you must show your work to get any credit. **PLEASE PRINT THIS DOCUMENT OFF IN LANDSCAPE MODE!**

THE CONTEST and REGISTRATION

- There is no cost for this contest.
- There are two grade categories: 9th and 10th graders will be graded in one category, while 11th and 12th graders will be graded in a second.
- All students will be informed of their score approximately one week after the date below, and the top-3 in each category will be officially recognized.

SUBMIT YOUR TEST AND ANSWERS EITHER ...

BY MAIL

Mike Round
13234 Long Street
Overland Park, KS 66213

*Entries must be post-marked
no later than April 14th.*

BY EMAIL

round12345@aol.com
*Entries must be received
no later than April 10th.*

QUESTIONS

High School Test Coordinator: Mike Round
(913) 515-3911 round12345@aol.com

1. Starting at the point, head left and move one unit. Turn left and move two units, and then turn left again and move three units. Repeat the process, always turning left before moving, and always moving 1, 2, and 3 units, respectively. How much area is fully enclosed by this “spiralateral” walking algorithm?

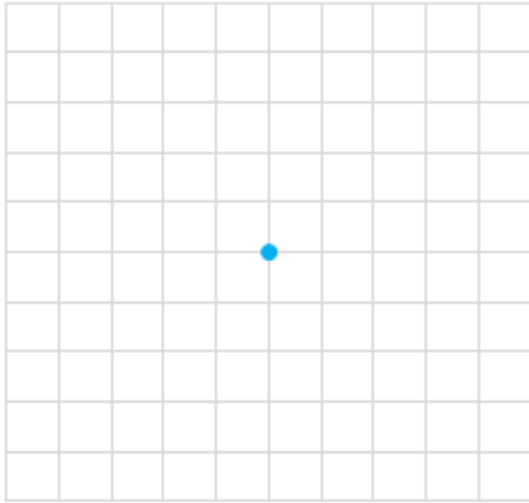

2. This mortality table shows the probability of dying in 20-year categories, assuming a person is alive at the start of the 20-year period. At birth, what is the probability a person will die between the ages 60 to 79?

Alive at this AGE	probability of dying in the next 20 years
0	1%
20	3%
40	10%
60	41%
80	98%

3. Imagine a 2x2 game of Tic-Tac-Toe, where "Winning" means two moves in either the same row or the same column.

If **X** goes first, what is the total number of moves **O** can make in all possible games of 2x2 Tic-Tac-Toe?



4. The staircase below needs carpeting. If each step is 6" high and 12" deep, and if the stairwell is 36" wide, how many square yards of carpet do I need to completely carpet all stairs?

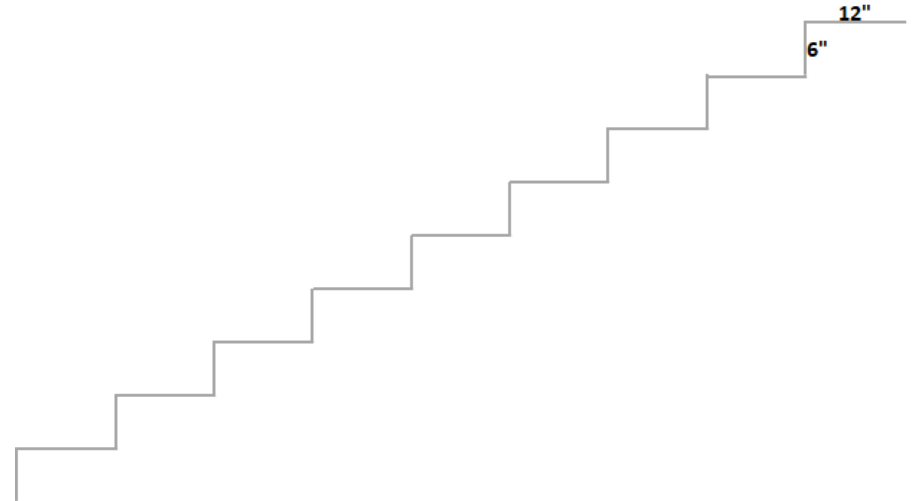

5. In the right triangle ABC below, if point C is tilted 30° clockwise, what is the area of triangle ABC'?

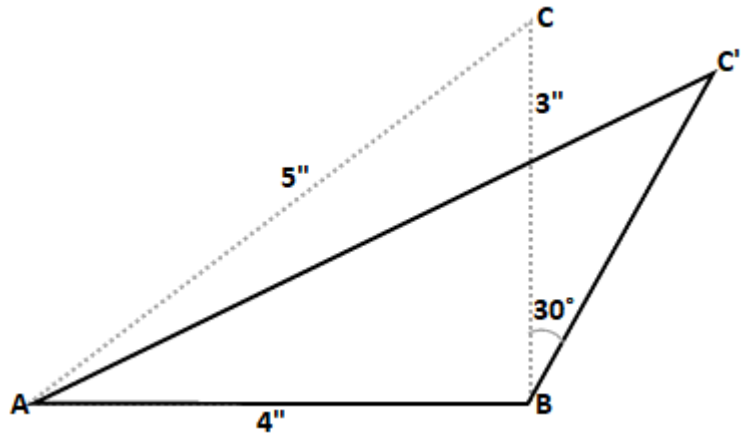

6. As measured from the outside tire to the center of a circle, the smallest circle the car below can make has a radius of 18'. When driving this circle, how much farther do the outside tires travel than the inside tires?

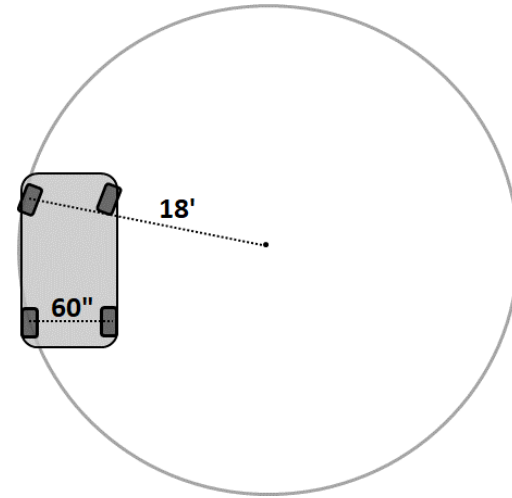

7. Built in the 1960s, the SR71 Blackbird could fly at high altitudes (90,000 feet) and at fast speeds (Mach 3.5). If the speed of sound at this altitude is approximately 979 feet / second, how fast could the plane fly in miles / hour?

8. The Standard Form of a quadratic equation is: $f(x) = ax^2 + bx + c$ while the Vertex Form of a quadratic equation is: $f(x) = a(x - h)^2 + k$. Derive the Vertex (h, k) in terms of $a, b,$ and c .

9. Starting at coordinates $(0,0)$, a line 1,000 units long is drawn as indicated. This line then branches into two separate lines (which form a 90° angle, as shown). Each of these lines is 60% the length of the previous segment. The process continues. Find the (x, y) coordinates of the indicated point.

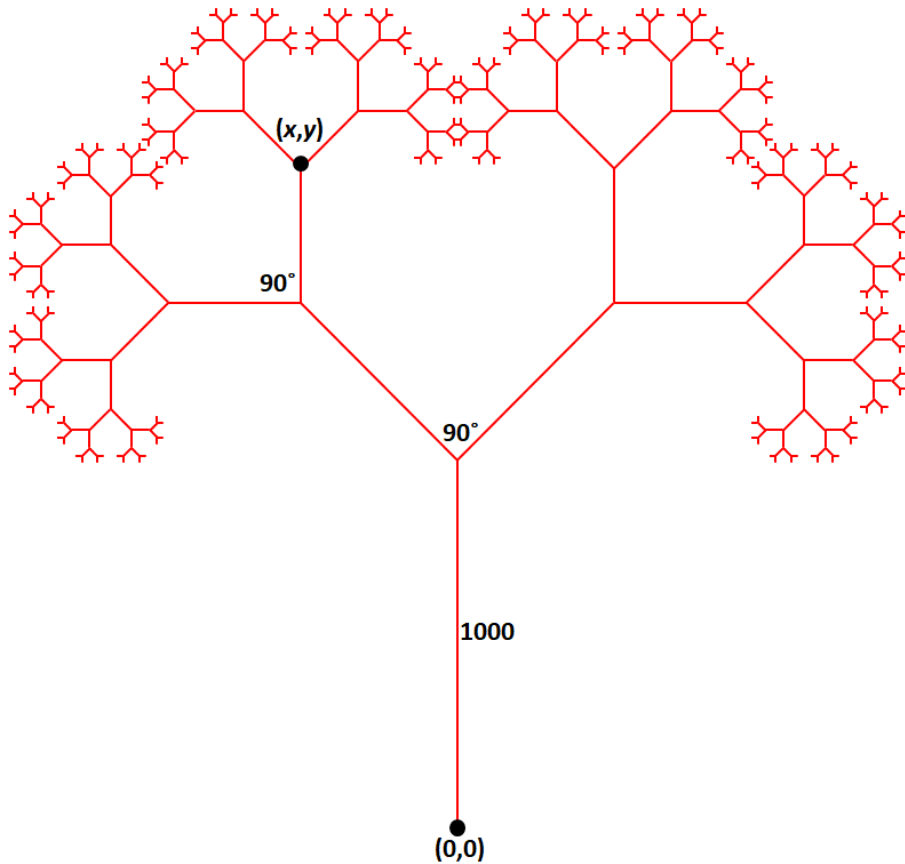

10. A solid sphere is perfectly embedded in a cube where each side is 6" long. What is the amount of unoccupied space within the cube?

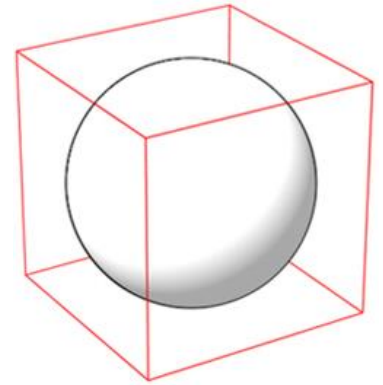

11. A business gift-wraps purchases during the Christmas season, and on Christmas Eve, the demand is huge. The three-stage process is described below. Each station cannot work on a present until the previous station has completed their function, and once a station is finished with one package, they immediately start on the next package (if it's available). The times each station actually worked on a gift are recorded below, with each station averaging 2 minutes / package. How many minutes did it take to have all three gifts wrapped?

Gift #	STATION A	STATION B	STATION C
	Worker sets up box and present	Robot fills box with stuffing	Worker seals and wraps box
1	1 min	2 min	1 min
2	4 min	2 min	2 min
3	1 min	2 min	3 min

12. Graph the function $r = 1 + 2\cos(2\theta)$ using polar coordinates below.

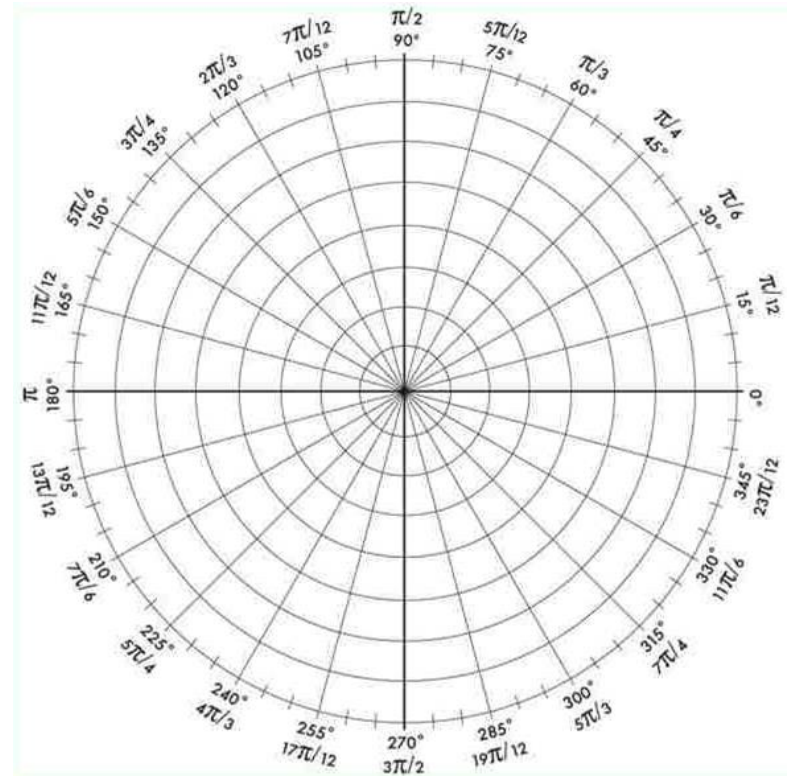

13. The point $(4,2)$ is closest to which point (x,y) on the function $y = |x|$?

14. It's the last semester of my senior year. I have accumulated 67 As, 31 Bs, and 15 Cs up to this point (in terms of credit hours), and am currently taking 15 credits (5 classes with 3 credits each). If I want to graduate with at least a cumulative 3.5 GPA, can I afford to get any Cs my last semester?

15. A line connects two points $(-2, -3)$ and $(3, 2)$. What are the two points on the line that break the line into thirds?

16. Find all points on the curve $(x - 3)^2 + (y - 4)^2 = 25$, where the slope of the tangent line at those points is $\frac{2}{3}$.

17. In the movie *"The Man Who Knew Infinity"*, the great mathematician Ramanujan talks about many things, including partitions (the number of ways of writing n as a sum of non-increasing integers). For example, below are the partitions for integers 1 through 4. How many ways are there to partition the number 7?

1	2	3	4
1	2	3	3 + 1
	1 + 1	2 + 1	2 + 2
		1 + 1 + 1	2 + 1 + 1
			1 + 1 + 1 + 1

18. What is the maximum amount of area a circle can intersect a square without crossing the square's diagonal?

19. I'm asked my semester grades and I reply "2 As and 2 Cs". My 10-credit semester consists of 4 classes, with 1,2,3, and 4 credits. What's my minimum and maximum weighted GPA

20. Imagine a clock centered on a grid with 12:00 at the point (0, 500) and 6:00 at the point (0, -500). What are the exact coordinates of 10:00?